

Operator's manual



TruTool F 125 (1A1)

english





Table of contents

1.	Safety	3
2.	Description	5
2.1	Correct use	6
2.2	Technical data TruTool F 125.....	7
3.	Tool assembly.....	8
3.1	Adjusting the hammer.....	8
4.	Operation	10
5.	Maintenance	11
5.1	Replacing plastic buffers.....	11
5.2	Replacing the carbon brushes	11
6.	Original accessories and wearing parts.....	12

Warranty

Replacement parts list

Addresses

1. Safety

- USA/CAN** ➤ Read the Operator's Manual and the general safety rules (Material number 1239438, red document) in their entirety before starting up the machine. Follow precisely the directions contained therein.

- Rest of the world** ➤ Read the Operator's Manual and the safety instructions (Material number 125699, red document) in their entirety before starting up the machine. Follow precisely the directions contained therein.
- The safety regulations according to DIN VDE, CEE, AFNOR and other regulations which are valid in individual countries should be adhered to.



Danger

Lethal danger due to electric shock!

- Remove the plug from the plug socket before undertaking any maintenance work on the machine.
- Check the plug, the cable and the machine for damage each time before the appliance is used.
- Keep the machine dry and do not operate in damp rooms.
- When using the electric tool outside, connect the fault current (FI) protective switch with a maximum breaking current of 30 mA.
-



Warning

Danger of injury possible due to improper handling!

- When working with the machine, wear safety glasses, hearing protection, protective gloves and work shoes.
- Do not plug in the plug unless the machine has been switched off. Pull out the mains plug after use.
-



Warning

Risk of injury to the hands!

- Do not place your hand into the processing line.
-



Caution

Damage to property possible due to improper handling!

The machine will be damaged or destroyed.

- Do not use the power cord to carry the machine.
 - Always guide the electric cord away from the back of the machine and do not pull it across sharp edges.
 - Arrange for start-ups and checks on manual electric tools to be carried out by a trained specialist. Only used the original accessories provided by TRUMPF.
-

2. Description

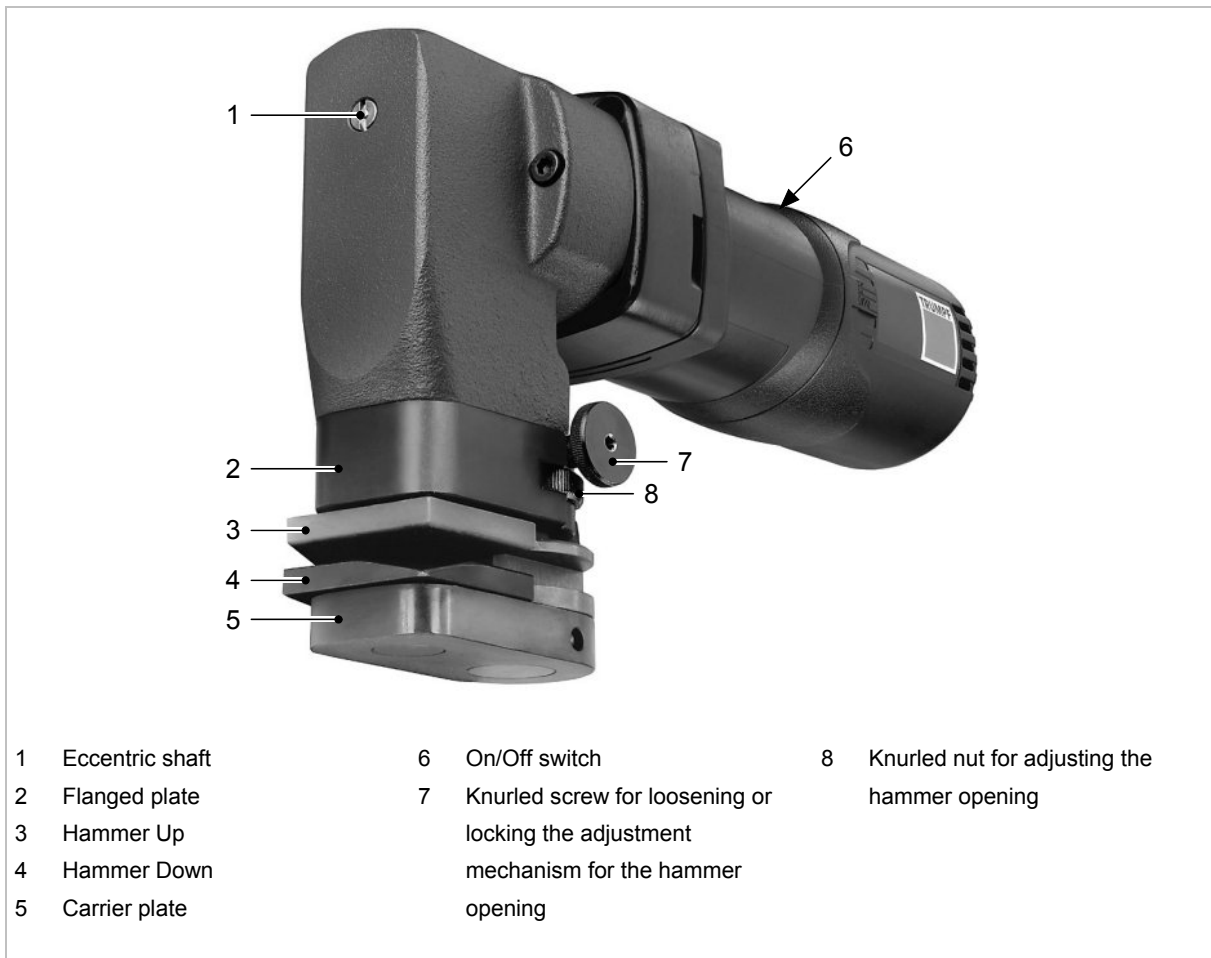

TruTool F 125

Fig. 38113

2.1 Correct use



Warning

Risk of injury!

- For processing and materials, only use machines which are named in "Correct use".

The TRUMPF Fold closer is an electric hand tool used for the following applications:

- Closing (hammering together) of pre-bent standing seams and angled standing seams on correspondingly pre-machined workpieces, e.g. ventilation ducts, housings, containers, etc.
- Closing of lock seams on straight or curved contours as well as in corners and angles.
- Hammering together of metal inserts for workpieces made of rubber, textile or plastic.

2.2 Technical data TruTool F 125

	Rest of the world			USA
	Values	Values	Values	Values
Voltage	230 V	120 V	110 V	120 V
Frequency	50/60 Hz	50/60 Hz	50 Hz	50/60 Hz
Maximum sheet thickness	1.25 mm	1.25 mm	1.25 mm	0.051 in
Max. tensile strength	400 N/mm ²	400 N/mm ²	400 N/mm ²	400 N/mm ²
Working speed	5-6 m/min	5-6 m/min	5-6 m/min	16-20 ft/min
Nominal power consumption	500 W	500 W	500 W	500 W
Stroke rate with idle run	2160/min	2160/min	2160/min	2160/min
Weight	2.8 kg	2.8 kg	2.8 kg	6.0 lbs
Max. folding thickness	5 mm	5 mm	5 mm	0.2 in
Max. folding height	40 mm	40 mm	40 mm	1.6 in
Protective insulation	Class II	Class II	Class II	Class II

Technical data

Table 1

Noise and vibration	Measured values in accordance with EN 60745
A-weighted sound level	Typically 81 dB (A)
A-weighted acoustic power level	Typically 85 dB (A)
Hand-arm vibration	Typically 2.6 m/s ²

Measured values for noise and vibration

Table 2

Note

The measured values specified above may be exceeded while working.

3. Tool assembly

3.1 Adjusting the hammer

Standing seam

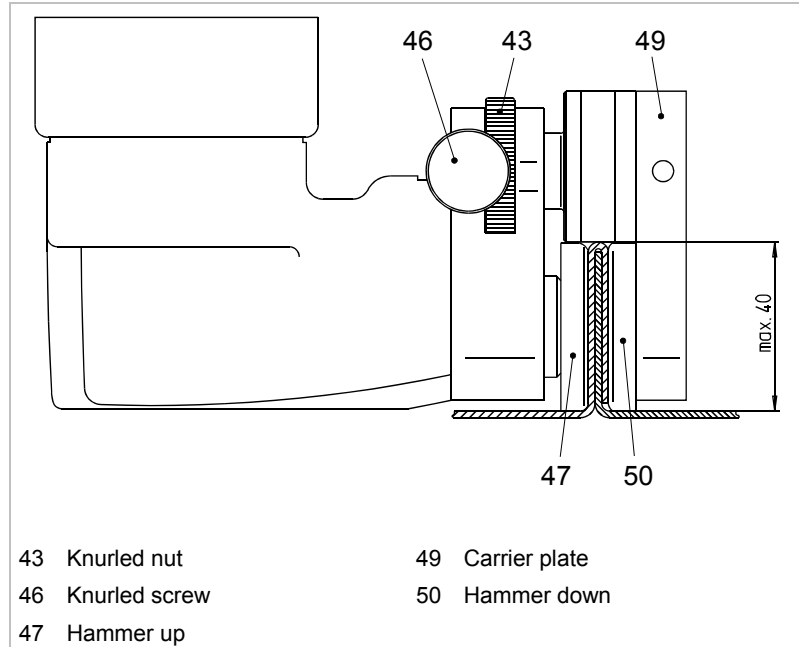

Standing seam

Fig. 11400

Adjusting hammer for standing seam

1. Loosen small knurled screw (46).
2. With the motor running, set the hammer opening to the desired seam thickness using the large knurled nut (43).
3. Lock small knurled screw (46) into place.
4. Close the lock seam.

Angled standing seam

Fig. 11401

The clearance between the upper and lower hammer must be adjusted depending on the sheet thickness and/or seam thickness.

**Adjusting the hammer
Angled standing seam**

1. Loosen small knurled screw (46).
2. Set maximum hammer opening with the large knurled nut (43).
3. Lock small knurled screw (46) into place.
4. Pre-seam the lock seam.
5. Re-loosen small knurled screw (46).
6. With the motor running, set the hammer opening to the desired seam thickness using the large knurled nut (43).
7. Lock small knurled screw (46) into place.
8. Close the lock seam.

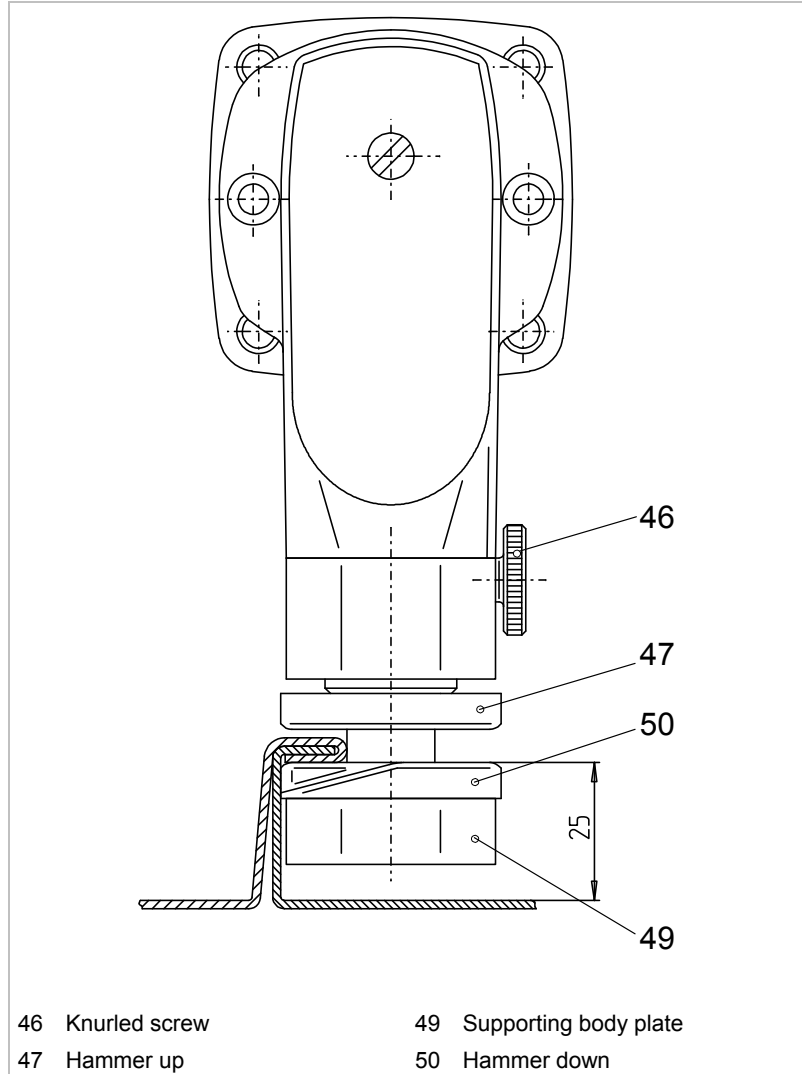
Plastic buffer

- Minor differences in seam thickness are balanced out through the use of a plastic buffer.

4. Operation

Switching on the TruTool F 125

- Move the On/Off switch to the front.

Working with the TruTool F 125

1. Guide the machine to the workpiece with the flattened edge foremost once the full rpm has been achieved.
2. Guide the machine along the lock seam.
3. Remove the machine from the workpiece at the end of the lock seam.

Switching off the TruTool F 125

- Move the On/Off switch to the rear.

5. Maintenance



Warning

Risk of possible injury due to improper repairs!

The machine does not function properly.

- Repairs should be carried out only by a trained specialist.
-

Are the lock seams no longer closing properly?

A worn-out plastic buffer is the cause.

- Mount new plastic buffer.

5.1 Replacing plastic buffers

The plastic buffer is for damping the hammer. This plastic buffer can begin to show wear over time. (see Fig. 11400, Pg. 8)

1. Loosen small knurled screw (46).
2. Loosen knurled nut (43).
3. Remove lower hammer.
4. Pull out upper hammer.
5. Remove plastic buffer with a screwdriver.
6. Push in new plastic buffer.
7. Put upper hammer in place.
8. Insert lower hammer.
9. Close knurled nut (43).
10. Tighten knurled screw (46).

5.2 Replacing the carbon brushes

The machine remains at standstill when the carbon brushes are worn out.

- Have the carbon brushes checked and replaced as needed by a trained technician.

6. Original accessories and wearing parts

Designation	Original accessories delivered	Wearing parts	Optional	Material-number
Plastic buffer	+	+		105449
Hammer up	+	+		0102964
Hammer down	+	+		0105448
Case	+			971396
Operator's manual	+			1254079
Safety information (red document), other countries	+			125699
Safety information (red document), USA	+			1239438

Original accessories, wearing parts and optional items

Tab. 3

Ordering wearing parts To ensure fast delivery of the correct original and wearing parts:

1. Give the order number.
2. Enter further order data:
 - Tension data
 - Number of pieces
 - Machine type
3. Give complete dispatch data:
 - Correct address.
 - Required delivery type (e.g. air mail, courier, express mail, ordinary freight, parcel post).
4. Send the order to the TRUMPF representative office. For TRUMPF service addresses, see the address list at the end of the document.